

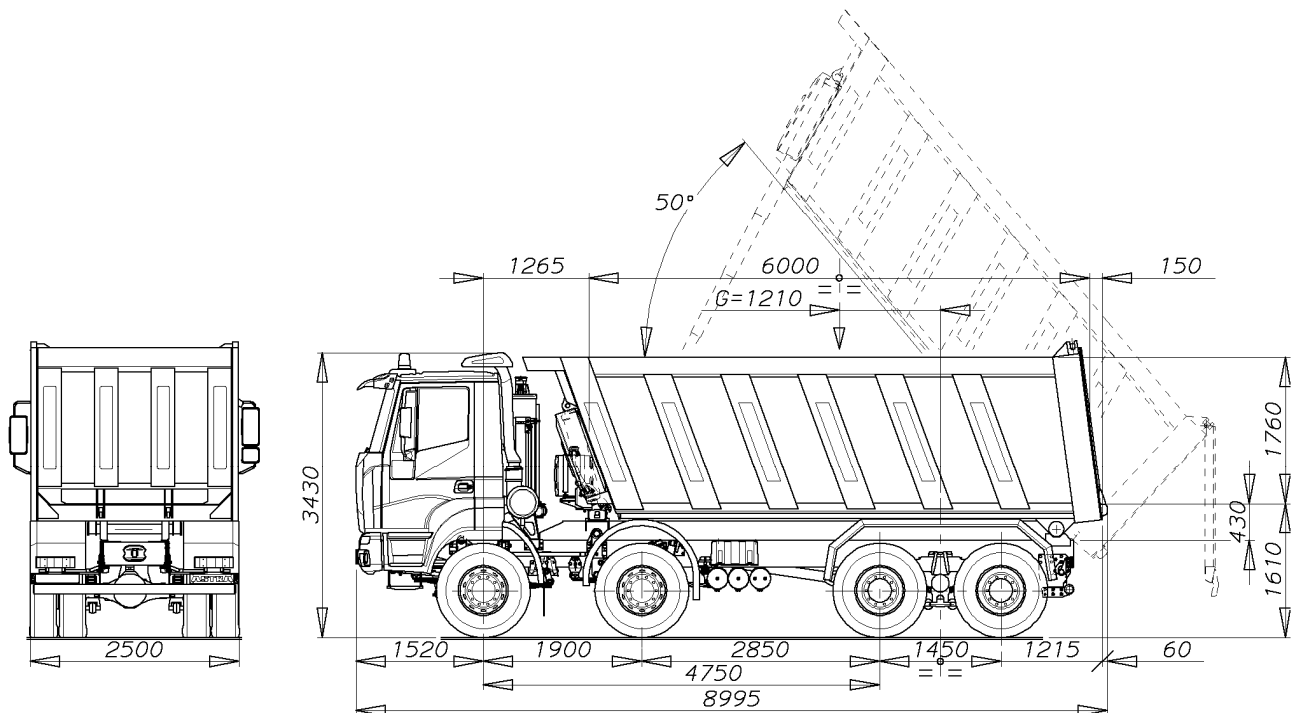

P1303113

CANTONI & C
BOFFALORA-T. (MI) ITALY

00632004

REAR TIPPER
"PF SEMIROCCIA"
HD9 84.42**TECHNICAL DATA**

- LIFTING** :
- Frontal telescopic cylinder.
 - Pneumatic, modulated body descent control.
 - Safety cable at the end of lifting.
 - Stabiliser bar.
 - Tipping time: 30 sec
- SUBFRAME** :
- Side frame in bent steel sheet.
 - Anti-torsion cross-member in the back side.
 - Mixed type frame fixing (front screws with springs).
- DUMP-BODY:**
- Capacity, 24 cu.m.
 - Inside dimensions, 5840 x 2310 mm
 - Structure in bent steel sheet.
 - Body floor in antiabrasion steel (HB 450), thickness 8 mm
 - Boards in antiabrasion steel (HB 400), thickness 5 mm
 - Front board equipped with cab protection roof and spare wheel holder.
 - Fixed sideboards.
 - Rear board with automatic unhooking device.

| WEIGHTS (kg) | Total | 1°+2°Axle | 3°+4°Axle |
|--|-------|-----------|-----------|
| Dump body | 6000 | 1860 | 4140 |
| Net weight of the dump truck | 17300 | 8960 | 8340 |
| Payload | 32700 | 8740 | 23960 |
| G.V.W | 50000 | 17700 | 32300 |
| Max allowed weights (Front/Rear) | | 18000 | 33000 |

- Dimensions and weights are not binding and may undergo variations.